

# SERPAC A-41

Electronic Enclosures

NOTES:

1. WHEN MACHINING OR "I" PLATE MODIFICATIONS ARE REQUIRED, DIMENSION FROM THE CENTER OF THE ENCLOSURE

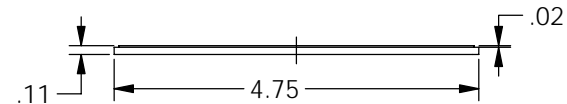
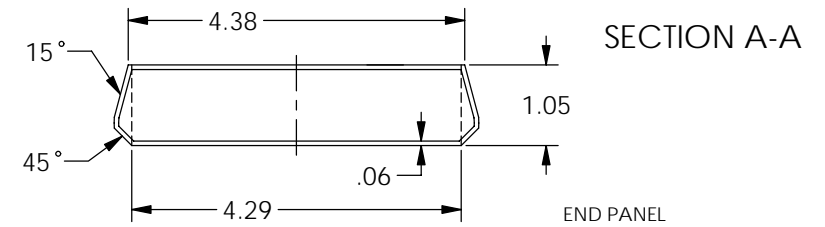
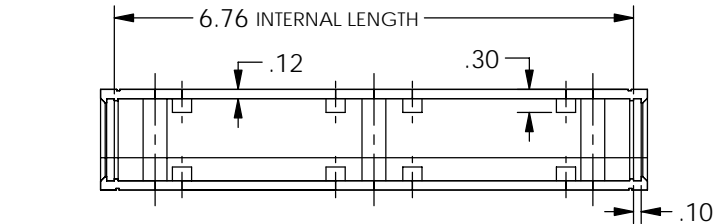
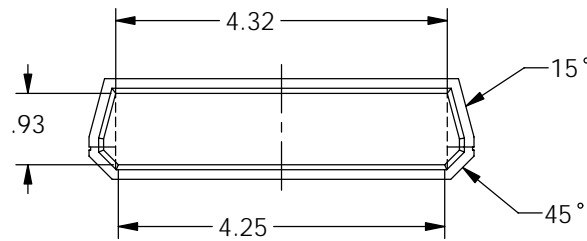
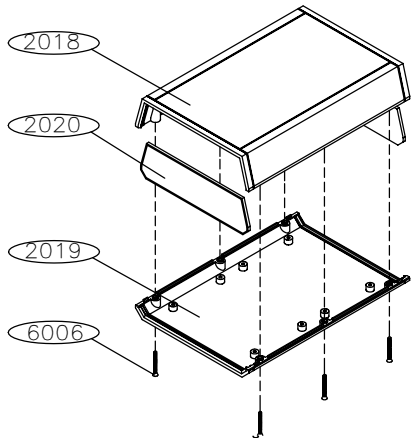
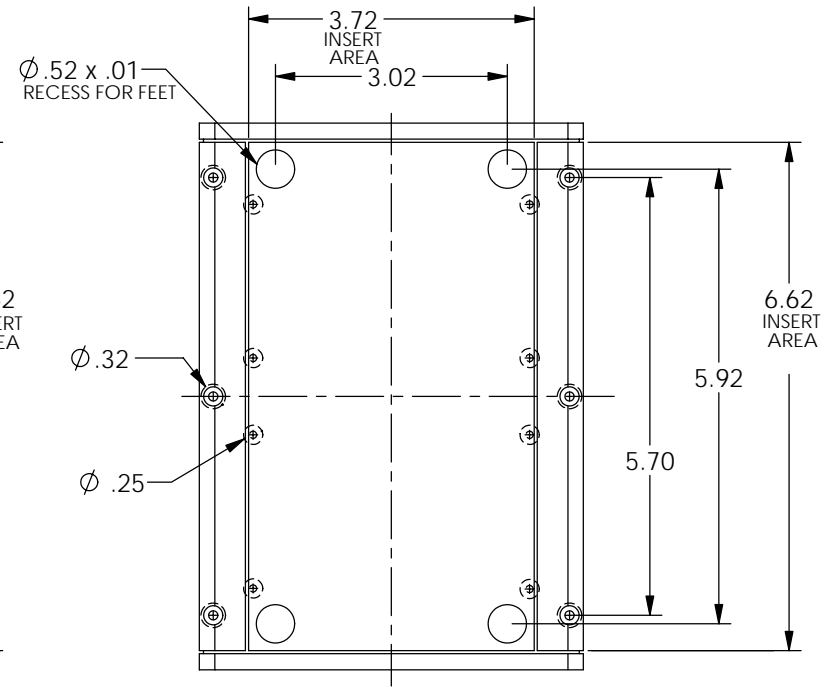
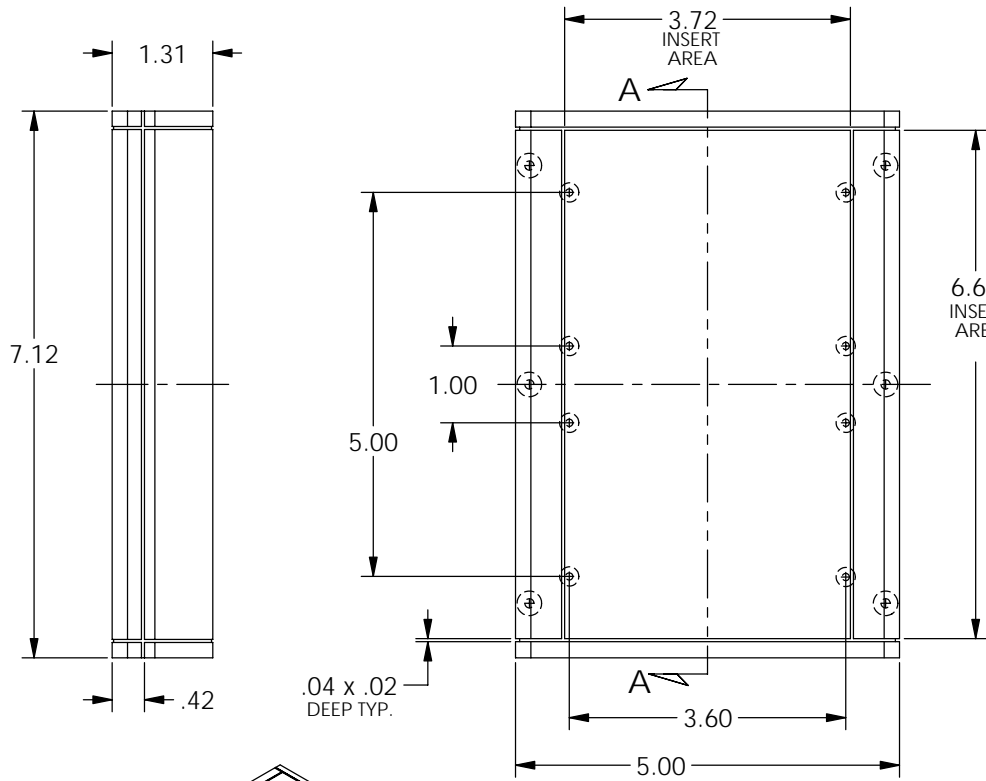

| PART NO. | DESCRIPTION | PART NO. | ACCESSORIES (NOT SHOWN) |
|----------|-------------|----------|-------------------------|
| 2018     | TOP         | 51       | FEET                    |
| 2020     | END PANEL   | 2020IR   | INFRARED PANEL          |
| 2019     | BOTTOM      | 2020CL   | CLEAR PANEL             |
| 6006     | SCREW       | 2020DB9  | DB9 CUTOUT PANEL        |
|          |             | 2020DB25 | DB25 CUTOUT PANEL       |